



THE STRONGEST LINK.

STAHL

CAMERAS AND CCTV SYSTEMS

For hazardous and industrial areas of production

R. STAHL: THE EXPLOSION PROTECTION EXPERT

A provider of products, systems and services in the field of explosion protection, R. STAHL is one of the leading companies worldwide in this area.

Our comprehensive product portfolio includes explosion-protected cameras, Human Machine Interfaces, switchgear, lighting systems, control units as well as complete explosion-protected system solutions.

With subsidiaries in more than twenty countries, R. STAHL can offer its customers across the globe customised sales and project management service for any requirements concerning explosion-protected products.

CONTENT

CCTV SYSTEM SOLUTIONS	04
OFFSHORE / ONSHORE	06
REFINERIES.....	10
CHEMICAL / PHARMACEUTICAL INDUSTRIES	12
CAMERA HIGHLIGHTS	16
CAMERA OVERVIEW.....	18
ACCESSORIES.....	20
SOFTWARE SEETEC CAYUGA	22
ONE-STOP SUPPLIER.....	24
R. STAHL WORLDWIDE.....	26



R. STAHL CAMERA SYSTEMS FOR HAZARDOUS AREAS



R. STAHL Camera Systems can provide all types of CCTV systems possible in hazardous areas.

In order to be able to provide the best possible video surveillance for each requirement we have devised the OPEN CCTV SYSTEM – we use this system to develop tailor-made CCTV systems that exactly suit your requirements.

We are a one-stop supplier – except for installation, we provide all services such as project engineering, planning, documentation, FAT, SAT and commissioning.



WHAT IS THE OPEN CCTV SYSTEM?

CCTV SYSTEM SOLUTIONS



Anyone dealing with CCTV and camera systems will know that it is not a single camera that ensures better security, but a system solution.

R. STAHL Camera Systems specialises in system solutions.

We can make use of 80 years of experience in the field of explosion protection and many years spent acquiring CCTV expertise to design CCTV systems from a variety of components to meet your monitoring needs.

For this we have developed the OPEN CCTV SYSTEM, which allows us to combine those components that are ideally suitable for your needs. Ranging from the smallest compact camera to a high-

resolution thermal imaging camera, our portfolio meets almost every requirement in the field of monitoring and surveillance.

Be it video surveillance or leakage monitoring, external monitoring, flexible access from many points or redundant server structures – our OPEN CCTV SYSTEM contains a great many options.

Our cameras have an “open” design – they can communicate with (almost) all cameras and hardware components available, regardless of protocol.

This is the basis for our OPEN CCTV SYSTEM.



OPEN CCTV SYSTEM

OPEN CCTV SYSTEM FOR INDIVIDUAL SOLUTIONS

ONE-STOP SUPPLIER FOR HAZARDOUS AREAS

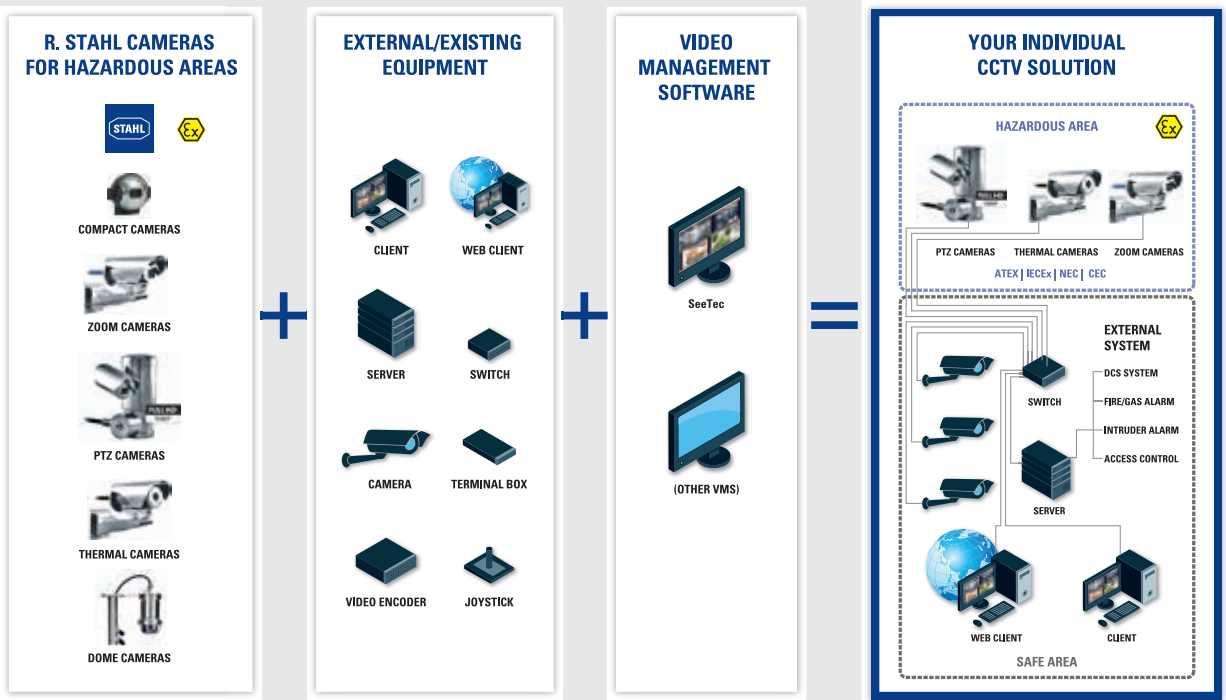

OFFSHORE / ONSHORE

OIL & GAS SYSTEM SOLUTIONS

Extreme ambient conditions, fluctuating temperatures and salt spray make monitoring on offshore and onshore drilling rigs difficult – R. STAHL cameras have been designed to function reliably in these ambient conditions.



SYSTEM SOLUTION OFFSHORE DRILLING RIG

ACCESS FROM SEVERAL LOCATIONS



NEW

FULL HD

ONVIF

This CCTV system was designed for great temperature fluctuations and the rough ambient conditions prevailing on a drilling rig, zone 1.

This system required a high-resolution image quality, separate surveillance at three different locations and central storage.

CHALLENGE:

- Zone 1 CCTV system
- One monitoring option per operating unit
- Data transmission across wide distances
- Very detailed camera surveillance

SOLUTION:

- Combination of PTZ and AFZ cameras in Full HD
- Media converter in zone 1
- Via switch to FO cable to control stations far away
- Central data storage on one server

R. STAHL Camera System Solution

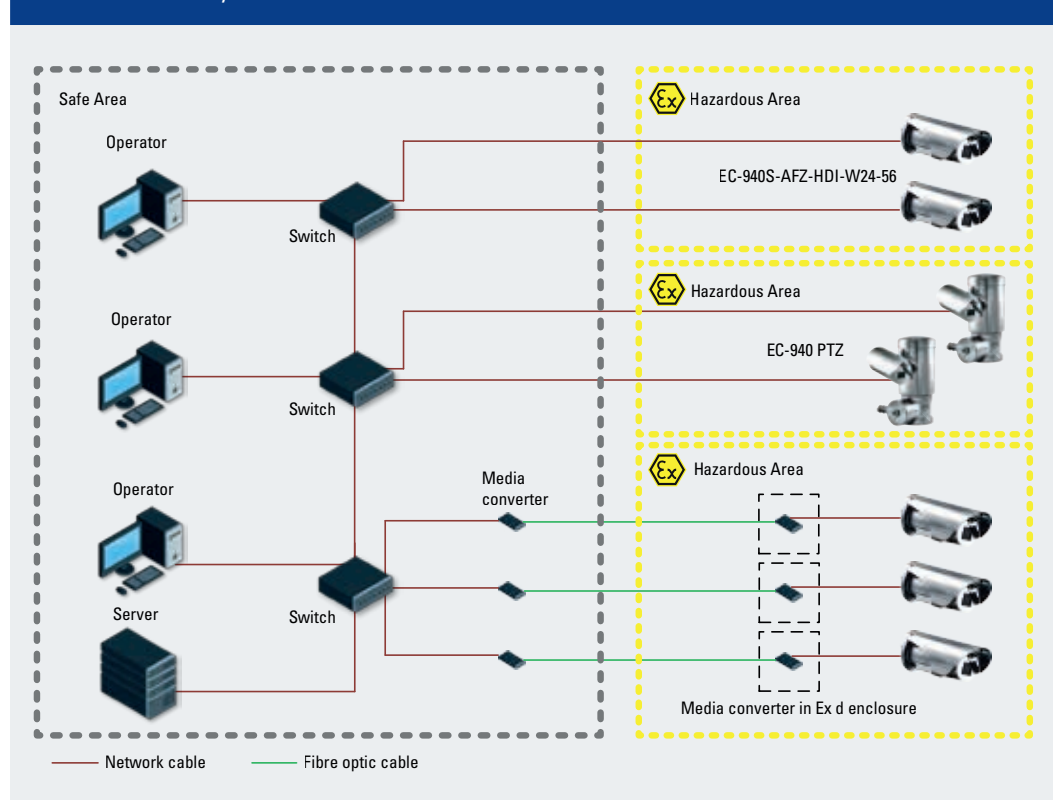

SYSTEM SOLUTION A CONSTANT EYE ON THE LOAD

BY SPECIAL OIL DAMPER

Clear images aligned to the vertical were the critical issue for this real-time monitoring system.

Our specific oil damper that keeps the camera in a constant vertical position was the key to meeting this requirement.



CHALLENGE:

- Clear images of the load
- Real-time monitoring in extreme environment, zone 1
- Cameras for monitoring processes and loading and for detailed monitoring

SOLUTION:

- AFZ cameras for process monitoring
- Compact camera for detailed monitoring
- Temperature range (-40 °C to + 75 °C / -40 °F to + 167 °F)
- Camera pointing towards load supported by special oil damper
- Real-time images on 12" monitor



R. STAHL Camera System Solution

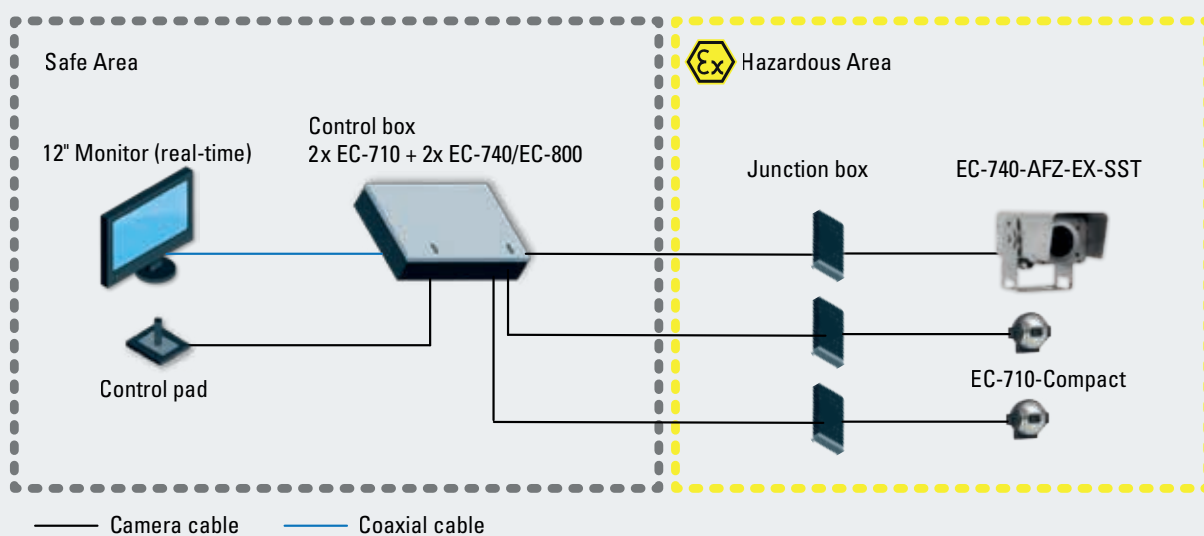

SYSTEM SOLUTION REAL-TIME MONITORING

IN ZONE 1



This system solution was developed to control all drilling processes and provide comprehensive video monitoring of critical areas.

All live images were transferred to the control centre without delay.

CHALLENGE:

- Monitoring of processes and drilling in zone 1
- Real-time data transmission to three control monitors, one of which in zone 1

SOLUTION:

- AFZ and PTZ cameras for process monitoring (-40 °C to + 75 °C / -40 °F to + 167 °F)
- Analogue data transmission of real-time images
- Easy on-site assembly

R. STAHL Camera System Solution

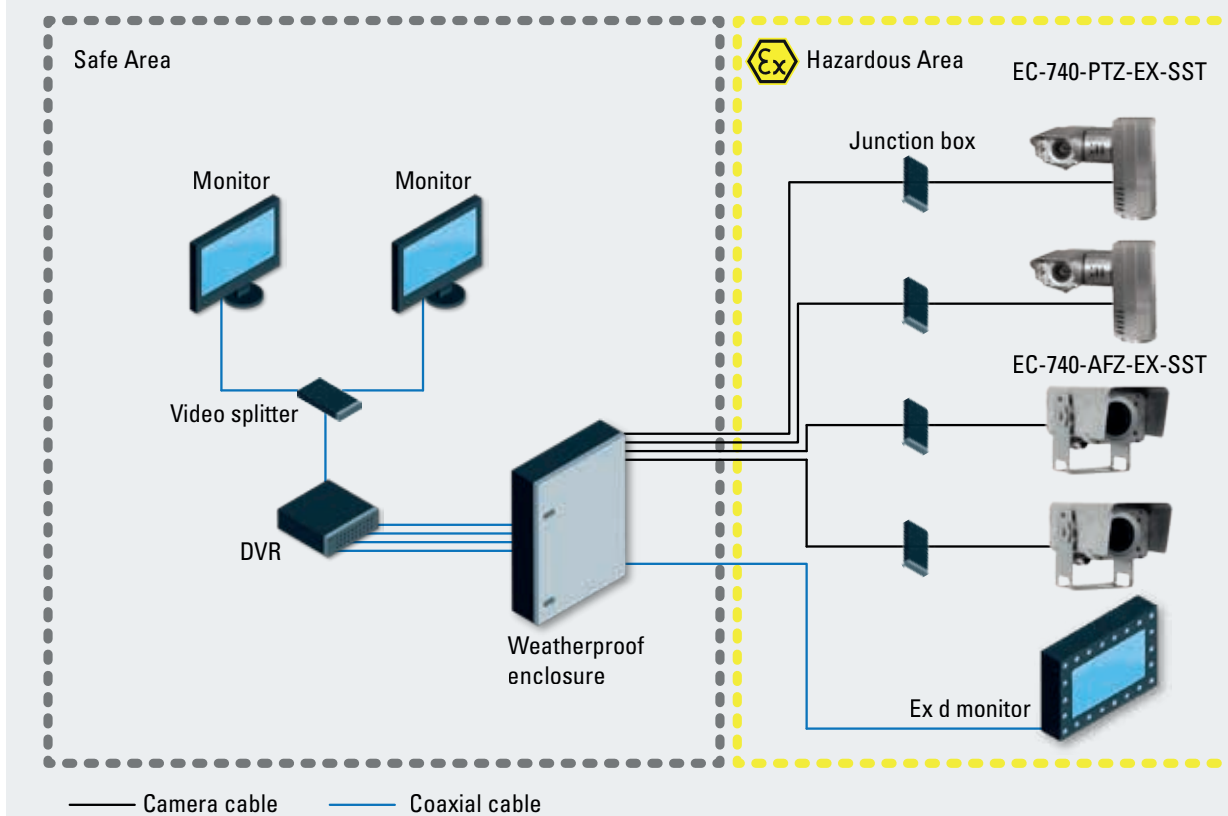

REFINERIES



We design complete video surveillance systems for reliable 24/7 operation in refineries, with guard tours and video management software.

Our open CCTV system concept allows for seamless integration of Ex and non-Ex cameras, a combination of fire and gas alarm systems and an individual adaptation of the recording settings – as well as reliable data transmission across wide distances via optical fibre.

SYSTEM SOLUTION PROCESS AND DETAILED MONITORING

WITH REDUNDANT CONTROL

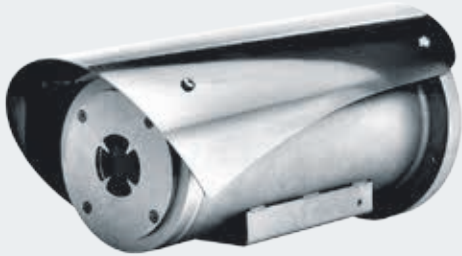

NEW

HIGH RES

ONVIF

This system was used to monitor process changes in a hazardous area by means of thermal imaging cameras and PTZ cameras.

Redundant control was provided at the control centre.

CHALLENGE:

- Redundant monitoring in network
- Data transmission across greater distances
- On-site control and operation in hazardous area

SOLUTION:

- Thermal imaging and PTZ cameras as IP version (Full HD)
- Data transmission via FO
- Redundant monitoring via switch

R. STAHL Camera System Solution

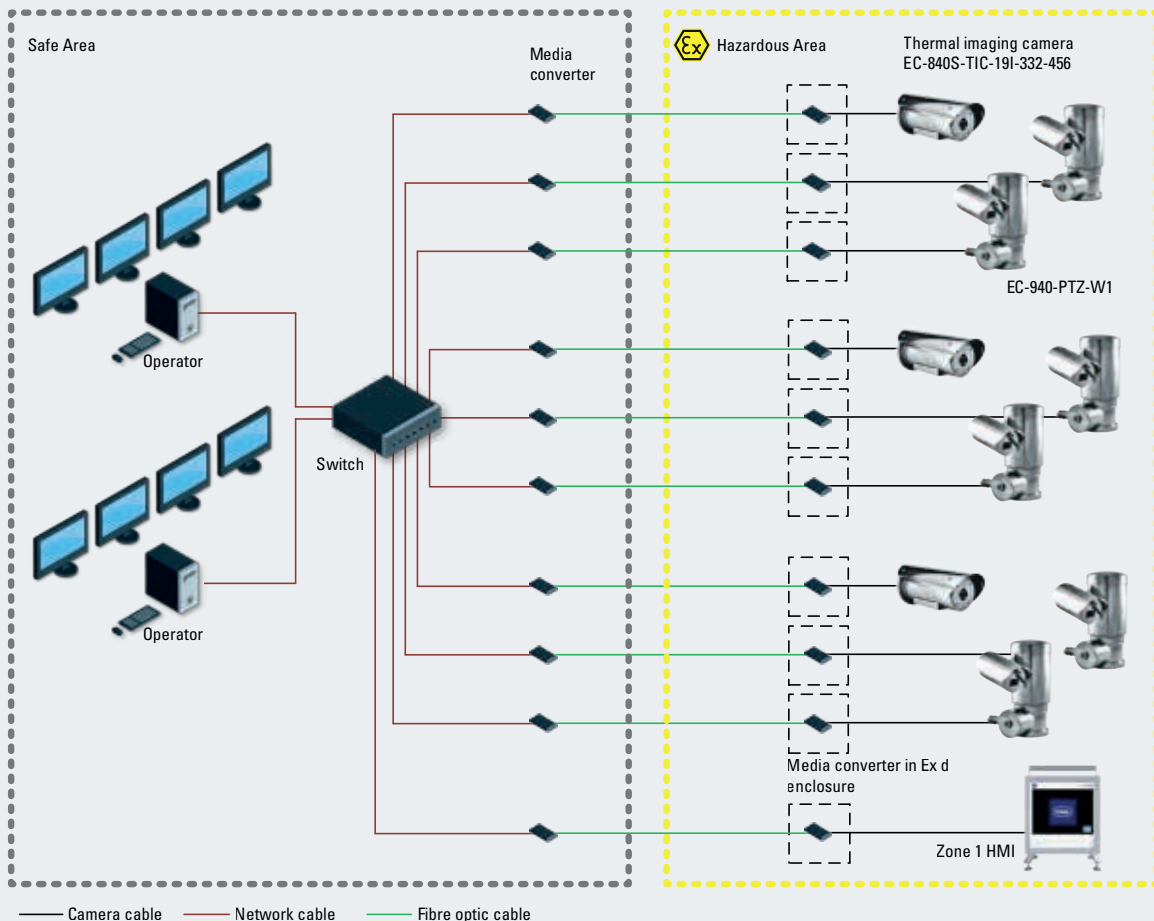

CHEMICAL / PHARMACEUTICAL INDUSTRIES

With our small, compact cameras that can withstand temperatures of up to +75 °C / +167 °F, we are a major supplier for fractionating columns and batch reactors.

These cameras can be used to constantly monitor all processes, particularly during the critical starting phase, so that, for example, foam generation is noticed instantly.



INSPECTION WINDOW MONITORING

LIVE REDUNDANT MONITORING IN HAZARDOUS AREA



Inspection window monitoring is a standard in chemical and pharmaceutical plants.

With this system solution, each batch reactor was monitored with the smallest compact camera world-wide, and the images were transmitted live to the system.

Exicom HMIs were used for monitoring in the field, whilst parallel live monitoring was taking place at the control centre.

CHALLENGE:

- Inspection window monitoring, zone 1
- Requiring little space
- Data transmission to control monitors in the field
- Explosion-protected HMIs

SOLUTION:

- Compact cameras for inspection window monitoring at up to +75 °C / +167 °F
- Smallest Ex camera in the world with a diameter of 55 mm / 2.2"
- Installation of EXICOM HMIs in the field
- Monitoring with special video software

R. STAHL Camera System Solution

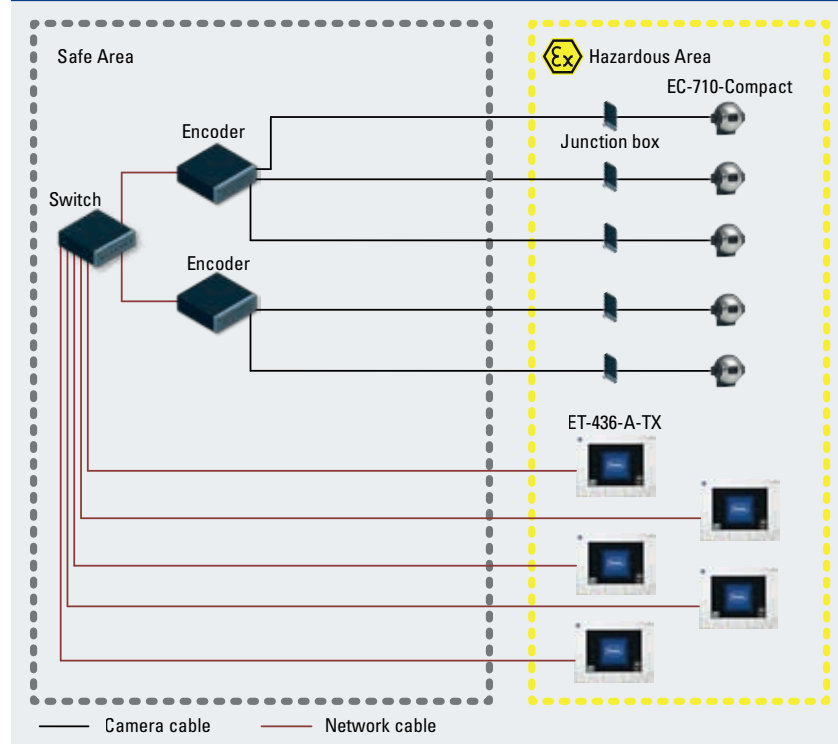

INSPECTION WINDOW AND PROCESS MONITORING

Monitoring of the production area with zoom cameras in hall A, in combination with inspection window monitoring at the batch reactor in hall B, and visualisation in the CCR (Central Control Room) on several monitors.

CHALLENGE:

- CCTV network system
- Video recording technology for tracking of incidents
- Powerful video management system

SOLUTION:

- Combination of AFZ and compact cameras in two hazardous areas
- Integration into an IP network
- Video recording via SeeTec VMS

R. STAHL Camera System Solution

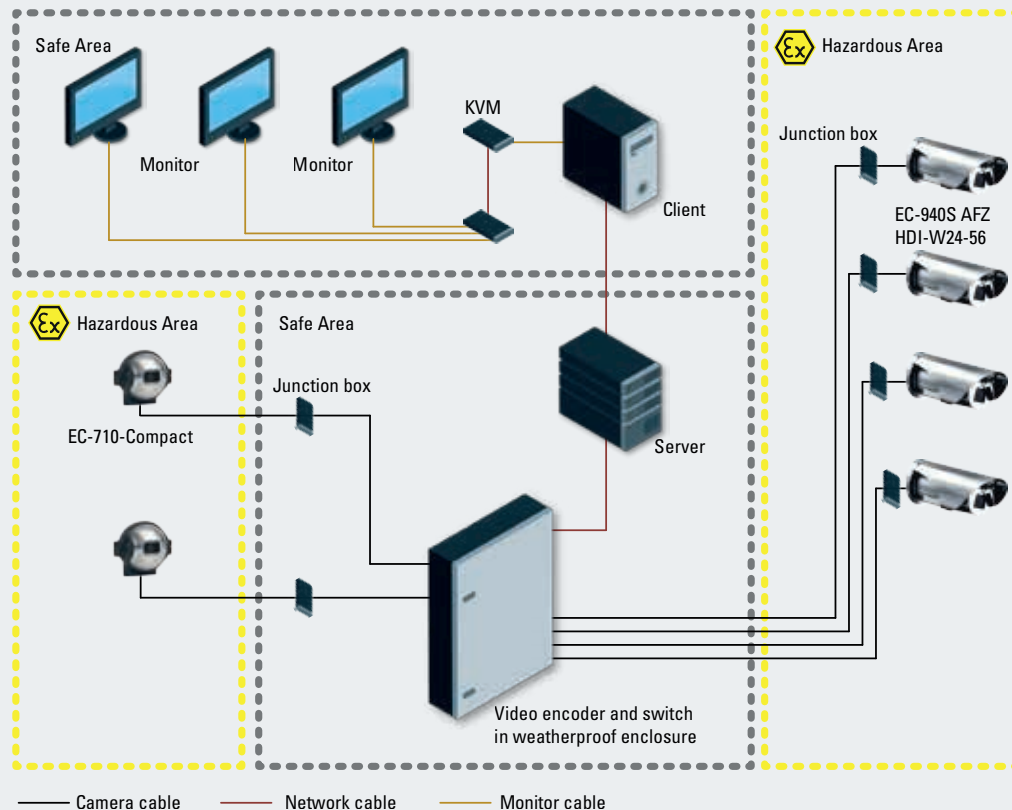

SYSTEM SOLUTION TEMPERATURE MONITORING

IN LOADING PROCESS

Leakages during loading must be spotted immediately, and the thermal imaging camera can address this task perfectly.

Our specially developed software identifies any changes in temperature and triggers an alarm in the PLC system.



NEW

HIGH RES

ONVIF

CHALLENGE:

- Monitoring of temperature during loading process
- Special software recognising changes in temperature
- Parallel monitoring at several control stations

SOLUTION:

- Highly sensitive thermal imaging cameras for hazardous areas
- Parallel control on network monitors
- Interface to PLC systems
- Application of a temperature monitoring software

R. STAHL Camera System Solution

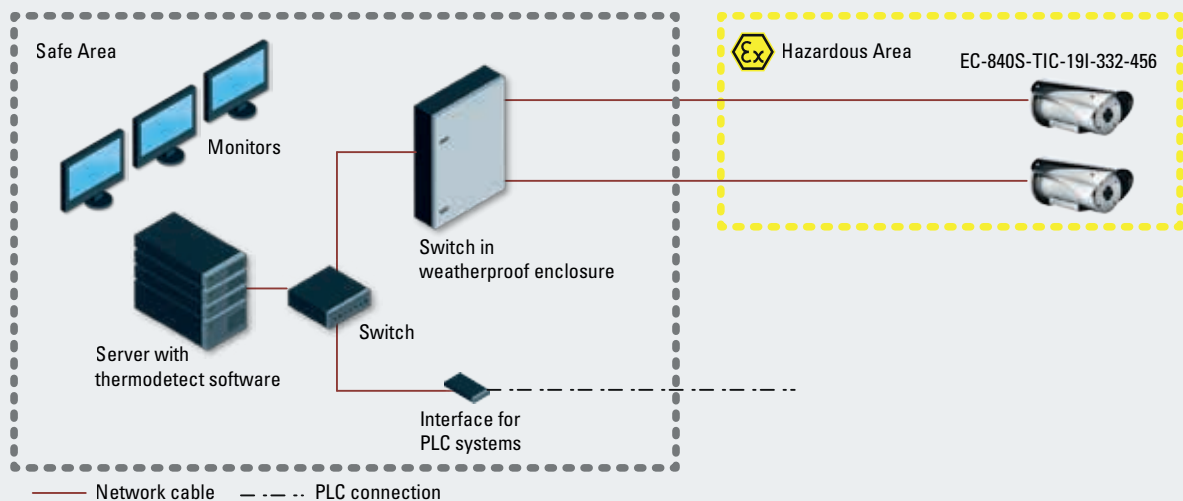

EX CAMERAS



We offer a complete portfolio of explosion-protected cameras – from the smallest Ex camera in the world, Full HD IP and dome cameras to the highly sensitive thermal imaging camera.

Compact Camera EC-710



- Diameter only 55 mm / 2.2"
- 7 versions with different viewing angles
- -40 °C to +75 °C / -40 °F to +167 °F
- Stainless steel enclosure

- Zone 1 / 2 / 21 / 22
- ATEX
- IECEx
- NEC
- CEC
- TR-EAC
- IP69K

AFZ Camera EC-940S-AFZ

NEW



- IP camera, Full HD (1920x1080)
- ONVIF, can be integrated worldwide
- -40 °C to +65 °C / -40 °F to +149 °F
- Stainless steel enclosure
- Also available as analogue version

- Zone 1 / 2 / 21 / 22
- ATEX
- IECEx
- NEC
- CEC
- IP68 / IP69

AFZ Camera EC-740-AFZ



- Analogue camera
- -40 °C to +75 °C / -40 °F to +167 °F
- Stainless steel / aluminium version
- 36x optical zoom

- Zone 1 / 2 / 21 / 22
- ATEX
- IECEx
- TR-EAC
- IP68 / IP69K

PTZ Camera EC-940-PTZ

NEW



- PTZ IP camera
- Full HD (1920x1080)
- ONVIF, can be integrated worldwide
- -40 °C to +60 °C / -40 °F to +140 °F
- Stainless steel enclosure
- 30x optical zoom

- Zone 1 / 2 / 21 / 22
- ATEX
- IECEx
- NEC
- CEC
- IP66

PTZ Camera**EC-740-PTZ**

- Analogue camera
- -40 °C to +75 °C / -40 °F to +167 °F
- Stainless steel / aluminium version
- 36x optical zoom

- Zone 1 / 2 / 21 / 22
- ATEX
- IECEx
- TR-EAC
- IP68 / IP69K

Thermal Imaging Camera**EC-840S-TIC****NEW**

- IP camera
- ONVIF, can be integrated worldwide
- -40 °C to +65 °C / -40 °F to +149 °F
- Stainless steel enclosure
- 640 x 512 resolution or 336 x 256 resolution
- Also available as analogue version

- Zone 1 / 2 / 21 / 22
- ATEX
- IECEx
- NEC
- CEC
- IP68 / IP69

Thermal Imaging Camera**EC-800-TIC**

- Analogue camera
- -40 °C to +75 °C / -40 °F to +167 °F
- Stainless steel / aluminium version
- 324 x 256 resolution

- Zone 1 / 2 / 21 / 22
- ATEX
- IECEx
- TR-EAC
- IP68

Thermal Imaging PTT Camera**EC-800-PTT**

- Analogue camera
- -40 °C to +75 °C / -40 °F to +167 °F
- Stainless steel enclosure
- 324 x 256 resolution

- Zone 1 / 2 / 21 / 22
- ATEX,
- IECEx
- TR-EAC
- IP68

Dome Camera**EC-750**

- Analogue camera
- -20 °C to +60 °C / -4 °F to 140 °F
- Stainless steel enclosure
- 360° endless
- 18x or 40x optical zoom (IP only)
- Also available as IP version

- Zone 1 / 2 / 21 / 22
- ATEX
- IECEx
- IP68

CAMERA OVERVIEW

	PRODUCT CODE	CERTIFICATED	PRODUCT TYPE	RESOLUTION	SIGNAL/ PROTOCOL	TEMPERATURE RANGE		
COMPACT CAMERA								
	EC-710-0XX	ATEX IECEX NEC / CEC TR-EAC	Analogue camera for extreme temperatures, available with 7 viewing angles	795 x 596 (PAL)	FBAS	-40 °C to +75 °C -40 °F to +167 °F		
AUTOFOCUS ZOOM CAMERAS								
 NEW	EC-940S-AFZ-HDI-W24-56	ATEX IECEX	AFZ camera, IP (Full HD)	1920 x 1080 (Full HD)	TCP/IP ONVIF Profile S	-40 °C to +65 °C -40 °F to +149 °F		
	EC-940S-AFZ-HDI-W2F-55	NEC CEC	(see above)					
	EC-940S-AFZ-1AP-W24-56	ATEX IECEX	AFZ camera, analogue	782 x 582 (PAL)	FBAS	-40 °C to +65 °C -40 °F to +149 °F		
	EC-940S-AFZ-1AP-W2F-55	NEC CEC	(see above)					
	EC-740-AFZ-EX-SST/ALU-485	ATEX IECEX TR-EAC	AFZ camera, analogue	782 x 582 (PAL)	FBAS	-40 °C to +75 °C -40 °F to +167 °F		
PAN / TILT / ZOOM CAMERAS								
 NEW	EC-940-PTZ-HDI-W1	ATEX IECEX	PTZ camera, IP (Full HD), 230 V	1920 x 1080 (Full HD)	TCP/IP ONVIF Profile S	-40 °C to +60 °C -40 °F to +140 °F		
	EC-940-PTZ-HDI-W2	ATEX IECEX NEC CEC	PTZ camera, IP (Full HD), 24 V	1920 x 1080 (Full HD)	TCP/IP ONVIF Profile S	-40 °C to +60 °C -40 °F to +140 °F		
	EC-740-PTZ-EX-SST/ALU-364	ATEX IECEX TR-EAC	PTZ camera, analogue	782 x 582 (PAL)	FBAS	-40 °C to +75 °C -40 °F to +167 °F		
THERMAL IMAGING CAMERAS								
 NEW	EC-840S-TIC-19A-332-456	ATEX IECEX	Thermal imaging camera, analogue	336 x 256 (PAL) 336 x 240 (NTSC)	FBAS	-40 °C to +65 °C -40 °F to +149 °F		
	EC-840S-TIC-19A-332-F55	NEC CEC	(see above)					
	EC-840S-TIC-19A-642-456	ATEX IECEX	Thermal imaging camera, analogue	640 x 512 (PAL) 640 x 480 (NTSC)	FBAS	-40 °C to +65 °C -40 °F to +149 °F		
	EC-840S-TIC-19A-642-F55	NEC CEC	(see above)					
	EC-840S-TIC-19I-332-456	ATEX IECEX	Thermal imaging camera, IP	336 x 256 (PAL) 336 x 240 (NTSC)	TCP/IP ONVIF Profile S	-40 °C to +65 °C -40 °F to +149 °F		
	EC-840S-TIC-19I-332-F55	NEC CEC	(see above)					
	EC-840S-TIC-19I-642-456	ATEX IECEX	Thermal imaging camera, IP	640 x 512 (PAL) 640 x 480 (NTSC)	TCP/IP ONVIF Profile S	-40 °C to +65 °C -40 °F to +149 °F		
	EC-840S-TIC-19I-642-F55	NEC CEC	(see above)					
	EC-800-TIC-EX-SST/ALU-485	ATEX IECEX TR-EAC	Thermal imaging camera, analogue	324 x 256 (PAL)	FBAS	-40 °C to +75 °C -40 °F to +167 °F		
PAN / TILT / THERMAL IMAGING CAMERAS								
	EC-800-PTT-EX-SST/ALU-485	ATEX IECEX TR-EAC	Thermal imaging camera, analogue	324 x 256 (PAL)	FBAS	-40 °C to +75 °C -40 °F to +167 °F		
DOMES CAMERAS								
	EC-750-PA-VI-PE	ATEX IECEX	Dome camera, analogue	782 x 582 (PAL)	FBAS	-20 °C to +60 °C -4 °F to +140 °F		
	EC-750-PA-IP-PE	ATEX IECEX	Dome camera, IP	782 x 582 (PAL)	TCP/IP	-20 °C to +60 °C -4 °F to +140 °F		
	EC-750-PA-IP-PE-40	ATEX IECEX	Dome camera, IP	782 x 582 (PAL)	TCP/IP	-20 °C to +60 °C -4 °F to +140 °F		

	IP SAFETY	ENCLOSURE MATERIAL	CABLE	INPUT VOLTAGE	ZOOM	ILLUMINATION	VIEWING ANGLE
	IP68 IP69K	Stainless steel	5 m multicable	12 V DC (+/-10 %)	–	1.5 lx (F/1.2 5600 K)	81° – 12° (H)
	IP66 IP68 IP69 (enclosure only)	Stainless steel	4 m armoured cable	12–24 V DC 24 V AC	10x optical	0.12 lx 1/30 s, 50 %	67° (H) – 7.6° (V)
	(see above)		4 m cable set	(see above)			
	IP66 IP68 IP69 (enclosure only)	Stainless steel	4 m armoured cable	12–24 V DC 24 V AC	10x optical	0.0004 lx 1/3 s (PAL) 0.0004 lx 1/4 s (NTSC)	52° (H) – 5.4° (V)
	(see above)		4 m cable set	(see above)			
	IP68 IP69K	Stainless steel / aluminium version available	5 m multicable	24 V DC	36x optical	1.4 lx F/1.6, 50 IRE	63.7° (H) – 2.3° (V)
	IP66	Stainless steel	–	230 V AC	30x optical	0.05 lx F/1.6 AGC on 1/30 s 50 %	63.7° (H) – 2.3° (V)
	IP66	Stainless steel	–	24 V AC	30x optical	0.05 lx F/1.6 AGC on 1/30 s 50 %	63.7° (H) – 2.3° (V)
	IP68 IP69K	Stainless steel / aluminium version available	3.5 m multicable	24 V DC	36x optical	1.4 lx F/1.6, 50 IRE	63.7° (H) – 2.3° (V)
	IP66 IP68 IP69 (enclosure only)	Stainless steel	4 m armoured cable	12–24 V DC 24 V AC	2/4x digital	Thermal imaging camera	17° (H) – 13° (V)
	(see above)		4 m cable set	(see above)			
	IP66 IP68 IP69 (enclosure only)	Stainless steel	4 m armoured cable	12–24 V DC 24 V AC	2/4/8x digital	Thermal imaging camera	32° (H) – 26° (V)
	(see above)		4 m cable set	(see above)			
	IP66 IP68 IP69 (enclosure only)	Stainless steel	4 m armoured cable	12–24 V DC 24 V AC	2/4x digital	Thermal imaging camera	17° (H) – 13° (V)
	(see above)		4 m cable set	(see above)			
	IP66 IP68 IP69 (enclosure only)	Stainless steel	4 m armoured cable	12–24 V DC 24 V AC	2/4/8x digital	Thermal imaging camera	32° (H) – 26° (V)
	(see above)		4 m cable set	(see above)			
	IP68	Stainless steel / aluminium version available	5 m multicable	24 V DC	2/4x digital	Thermal imaging camera	17° (H) – 13° (V)
	IP68	Stainless steel / aluminium version available	3.5 m multicable	24 V DC	2/4x digital	Thermal imaging camera	17° (H) – 13° (V)
	IP68	Stainless steel	5 m multicable	24 V DC	18x optical	0.01 lx ICR on F/1.6 1/4 s	48° (H) – 2.8° (V)
	IP68	Stainless steel	5 m multicable	24 V DC	18x optical	0.01 lx ICR on F/1.6 1/4 s	48° (H) – 2.8° (V)
	IP68	Stainless steel	5 m multicable	24 V DC	40x optical	0.01 lx ICR on F/1.6 1/4 s	60° (H) – 1.6° (V)

ACCESSORIES

HARDWARE



OIL-DAMPED CAMERA MOUNT FOR CRANES

For all 740 zoom cameras, R. STAHL offers oil-damped mounts. The sophisticated damping system holds the camera in a vertical position. It attenuates any vibrations caused by crane movement, and the crane operator receives clear images of the load being moved.



INSPECTION WINDOW MOUNT FOR COMPACT CAMERAS

For batch reactors, R. STAHL offers inspection window mounts for the compact cameras which are ideally suited for inspection window monitoring of critical process phases.



WASH & WIPER FUNCTION

The stainless steel version of the EC-740-PTZ can, as an option, be ordered with a wiper and spray nozzle. In addition, a five or ten litre water tank is available for zone 1 so that the front glass can be cleaned with remote function.

The EC-940S and EC-940-PTZ are fitted with a wiper ex-factory. A spray nozzle and a water tank are available as further options.



ANALOGUE, EXPLOSION-PROTECTED 7" AND 15" MONITORS

7" and 15" monitors support live monitoring and control of up to four cameras.

Up to 3 x EC-710 and 1 x EC-740-AFZ, or EC-800-TIC at the 7" monitor, and up to 1 x EC-710 and 3 x EC-740-AFZ, or EC-800-TIC at the 15" monitor.

Analogue signal transmission is particularly suitable for processes in hazardous areas where time is of the essence, since video images are produced without delay and in real time.

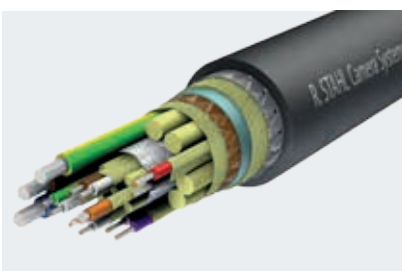

CABLE

Armoured and non-armoured multicables. The composition of the cable of twisted wires, insulation, shielding and coating, tailored for each application, is the basis of the cable's functionality. The portfolio ranges from armoured multi-ethernet cables for the Full HD IP cameras to the analogue multicable for the EC-740/800 series.



VIDEO SURVEILLANCE VIA POWERFUL SHARK PANEL PCS

Fitted with the new Intel® Core™-i7 processors, the powerful SHARK Panel PCs are ideally suited for network-based video surveillance.

With high-brightness display, multi-touch functions, brightness sensor, Bluetooth® and camera interfaces, the 438 Panel PCs are suitable for universal operation worldwide, in ambient temperatures ranging from -40 °C to +65 °C / -40 °F to +149 °F.



EX D ENCLOSURES

The explosion-protected Ex d enclosure system made of stainless steel or aluminium allows for the flexible installation of components from safe areas.

In this way, components that were originally only designed for installation outside of hazardous areas can now also be used inside hazardous areas.

We will develop the ideal Ex d enclosure for each component, on request also immediately operational.



EX E TERMINAL BOXES

Ex e terminal boxes, made from stainless steel or glass fibre reinforced polyester resin, are designed for the connection of individual or flexible wires in hazardous areas.

A connection directly at the Ex d enclosure makes sense and is technically possible; the individual components can thus be easily connected inside the enclosure.



CONTROL BOXES

The control box connects camera(s) and monitor and also supplies the connected camera(s) with power. Up to four cameras type -710 / -740 / -800 can be connected to the control boxes. In addition to the monitor, all necessary components can be fast and easily integrated in a single control box, thus drastically reducing the time needed for installation.

The control box is exclusively designed for installation outside of hazardous areas.



CAMERA MOUNTS

Various electropolished stainless steel mounts in AISI 316L are available for easy mounting of the cameras. In addition to wall mounts, pole adapters and corner-mount adapters are available.

SEETEC CAYUGA

VIDEO MANAGEMENT SOFTWARE



SEE MORE, UNDERSTAND MORE, ACT FASTER AND MORE EFFICIENTLY

SeeTec Cayuga can be used in a great variety of applications that go beyond the classic security field, and is thus one of our preferred video management systems.

A great many modules and interfaces result in highly professional, individual, scalable video management solutions for every conceivable area of application.

VENDOR INDEPENDENCE – AN OPEN SYSTEM

Just like R. STAHL's hardware platform, the SeeTec software is designed as an "open" system, making it easy for R. STAHL IP cameras as well as network cameras and video servers of almost all major manufacturers (ONVIF Profil S) and I/O modules, alarm triggers and video sensors to be operated inside one CCTV system.

Thus, individual, tailor-made system solutions are possible for every application – for completely new CCTV systems as well as the expansion/upgrade of existing ones.

UNLIMITED ACCESS

Various client types (e.g. Windows® client, web client, mobile client, smartphone types using iOS/Android) can be used to realise local access or access via the internet to the cameras. Here, data transmission between client and servers is always on the basis of encrypted connections.

Desktop virtualisation with Citrix and desktop connections are also supported.

SYSTEM STABILITY

Should a recording server fail, a failover server in hot standby mode can take over the recording of images. Even if the central administration server fails, the local systems will remain accessible in stand-alone mode.

COMPLEX ALARM SCENARIOS

SeeTec can be used to define complex alarm scenarios which, in the case of an alarm, start the simultaneous recording of any network cameras in the system or transmit alarms. Thus, reaction times are cut and dangerous situations can be defused sooner.

PRACTICAL SYSTEM MANAGEMENT

Multi-level administration for individual mapping of organisation structures. Expanded alarm scenarios enable users to individually map routines and workflows.

VIDEO ANALYSIS

SeeTec Cayuga has a simple video analysis integrated as a basic module. For further analysis, a great many modules are available in the system. These modules can be used for fast and reliable recognition of potential dangers, thus creating the basis for an efficient alarm management.

Your security staff's work is noticeably reduced, and valuable resources can be saved.

ONE-STOP SUPPLIER



SERVICE / MAINTENANCE

SIDE ACCEPTANCE TEST

COMMISSIONING / INSTRUCTION

CCTV CONCEPT

PROJECT ENGINEERING

SYSTEM CONFIGURATION

DOCUMENTATION

FACTORY ACCEPTANCE TEST

SYSTEM FINDER



We have designed the SYSTEM FINDER to enable us to quickly find the best possible solution for your needs. You describe your requirements with a few clicks and in a few sentences, this is automatically forwarded to the right person in our company, and you will receive a proposal or a quote promptly.

OUR EXPERTS



R. STAHL Camera experts will be happy to help.



Our colleagues will identify the right CCTV systems to meet your requirements. Just ask us.

HEADQUARTERS GERMANY

R. STAHL Camera Systems GmbH
Adolf-Grimme-Allee 8
50829 Cologne, Germany
T +49 221 76806 -1200
office@stahl-camera.de
stahl-camera.de

R. STAHL: YOUR GLOBAL PARTNER

We are at your service around the globe: with seven production sites, subsidiaries in 24 countries and 60 agencies. Our international employees understand your needs and offer you R. STAHL quality – no matter where you need it.





Thanks to this global presence, we realise international joint projects that include customers, planners, installation companies and operators from various countries. And we take care of the needs of everyone involved in the project – right on-site.

At the same time we ensure compliance with the various legal stipulations relevant for each project since we have international certifications and approvals available worldwide.



OUR PRODUCTION SITES:

R. STAHL

- | | |
|---|--|
|  Headquarters |  Subsidiary |
|  Production site |  Agency |



Germany - Waldenburg

Germany - Cologne

Germany - Wei



mar



Netherlands



Norway



India



USA



R. STAHL Camera Systems GmbH
Adolf-Grimme-Allee 8
50829 Cologne, Germany
T +49 221 76806 -1200
F +49 221 76806 -4200
stahl-camera.de